





## Thermicco



### nr: 9110

Ościeżnica okienna i balkonowa  
Window and balcony frame  
Fenster- und Balkonrahmenprofil  
Рама оконная и балконная  
Okenný a balkónový rám  
Toc fereastră, balcon  
Ablaktok

nr: 9110-0-1  

nr: 9110-0-2  

nr: 9110-OR-1  

nr: 9110-OR-2  

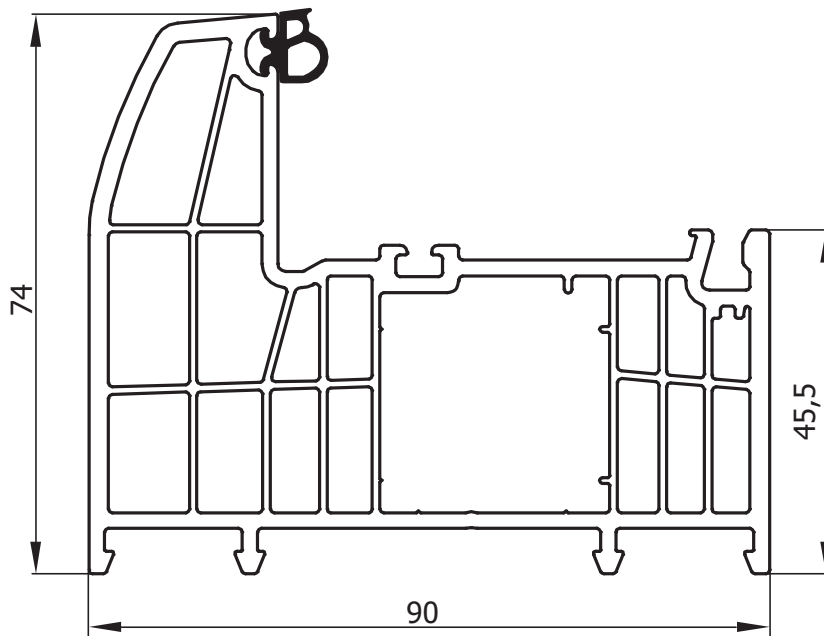



	Lx	Ly
90-100-10	0,98	1,64
90-101-10	1,80	1,78
90-106-10	2,09	1,28
90-107-10	2,87	1,82



## Thermicco

### nr: 9120

Skrzydło okienne i balkonowe  
Window and balcony sash  
Fenster- und Balkonflügelprofil  
Створка оконная и балконная  
Okenné a balkónové krídlo.  
Cercevea fereastră, balcon  
Ablakszárny

nr: 9120-0-1  

nr: 9120-0-2  

nr: 9120-OR-1  

nr: 9120-OR-2  

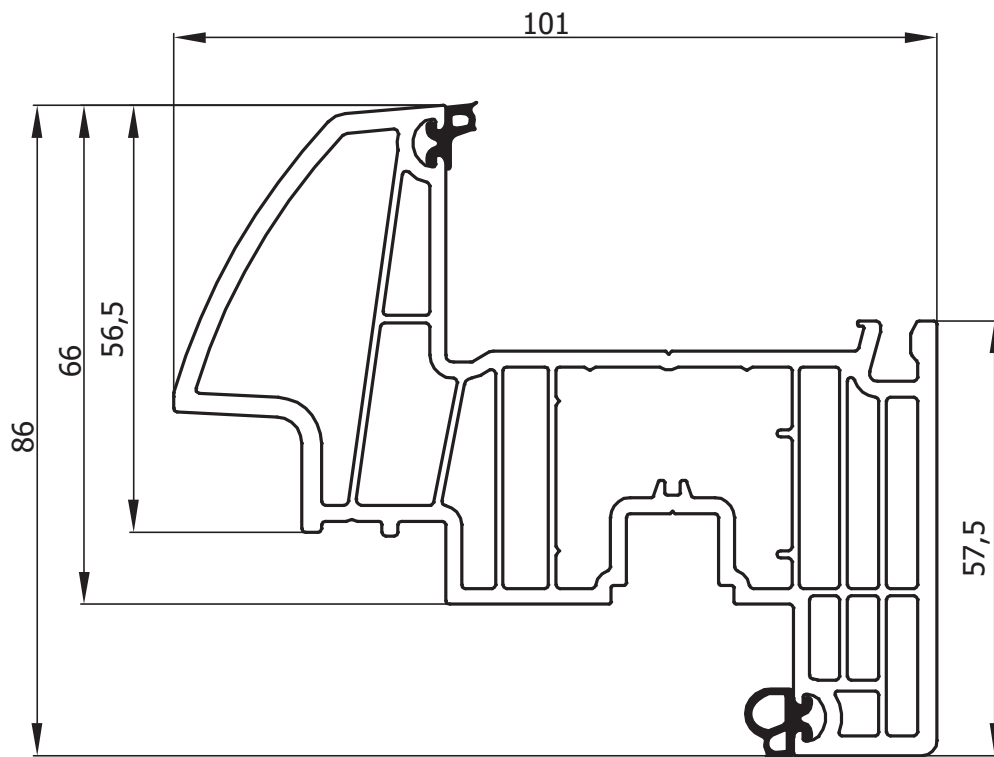

	Lx	Ly
90-100-10	0,98	1,64
90-102-10	0,76	1,23
90-106-10	2,09	1,28
90-107-10	2,87	1,82

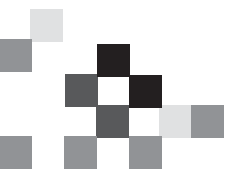

## Thermicco

### nr: 9124

Skrzydło drzwiowe Z otwierane do wewnątrz.

Door sash opened to the inside (Z)

Z-Türflügelprofil innenöffnend

Створка дверная Z, открываемая внутрь.

Dverové krídlo Z, otvárávé dovnútra

Cercevea ușă Z, deschidere interioară

Befelé nyíló ajtószárny

nr: 9124-0-1



nr: 9124-0-2

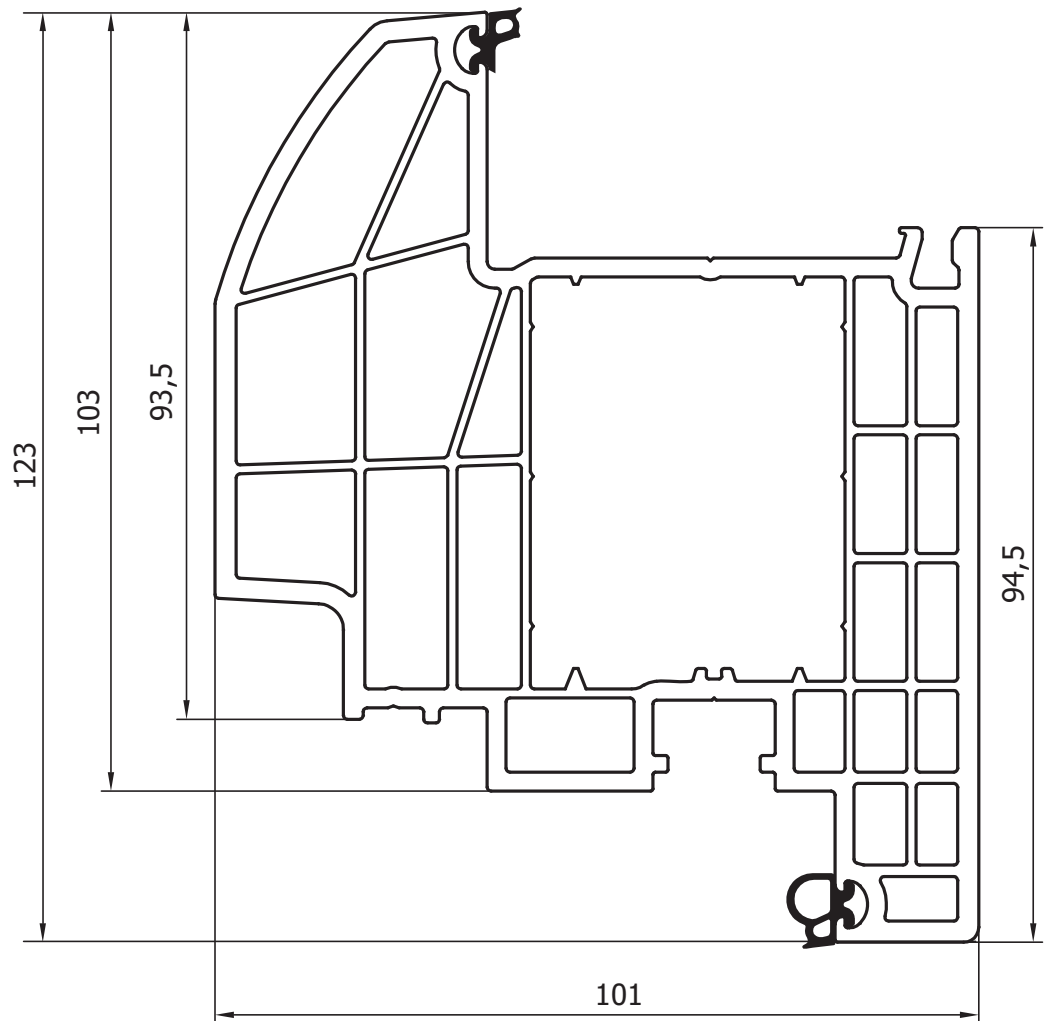

	Lx	Ly
90-240-10	8,65	12,27

## Thermicco

### nr: 9125

Skrzydło drzwiowe T otwierane na zewnątrz  
 Door sash opened to the outside (T)  
 T-Türflügelprofil außenöffnend  
 Створка дверная T, открываемая внéшни.  
 Dverové krídlo T otvárávé vonku  
 Cercevea ușă T, deschidere exterioră  
 Kifelé nyíló ajtószárny

nr: 9125-0-1



nr: 9125-0-2

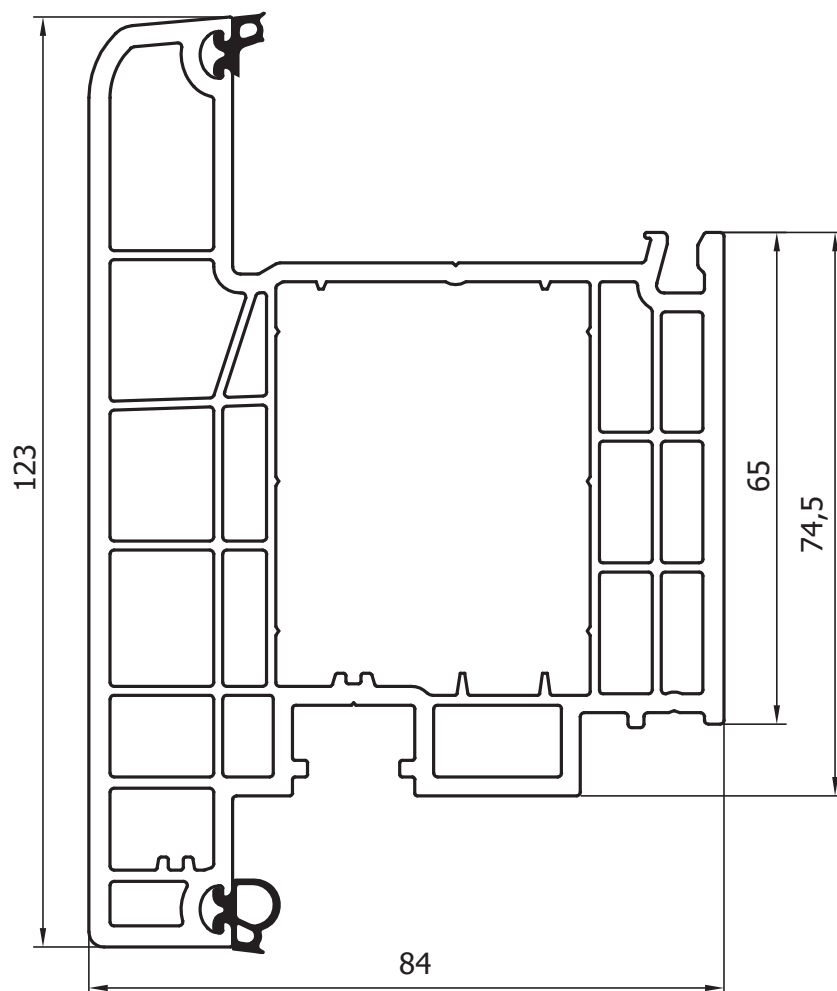

	Lx	Ly
90-240-10	8,65	12,27

## Thermicco

### nr: 9130

Słupek

Fixed mullion

Pfosten

Импост неподвижный

Pevný střípik

Montant

Osztó profil

nr: 9130-0-1



nr: 9130-0-2

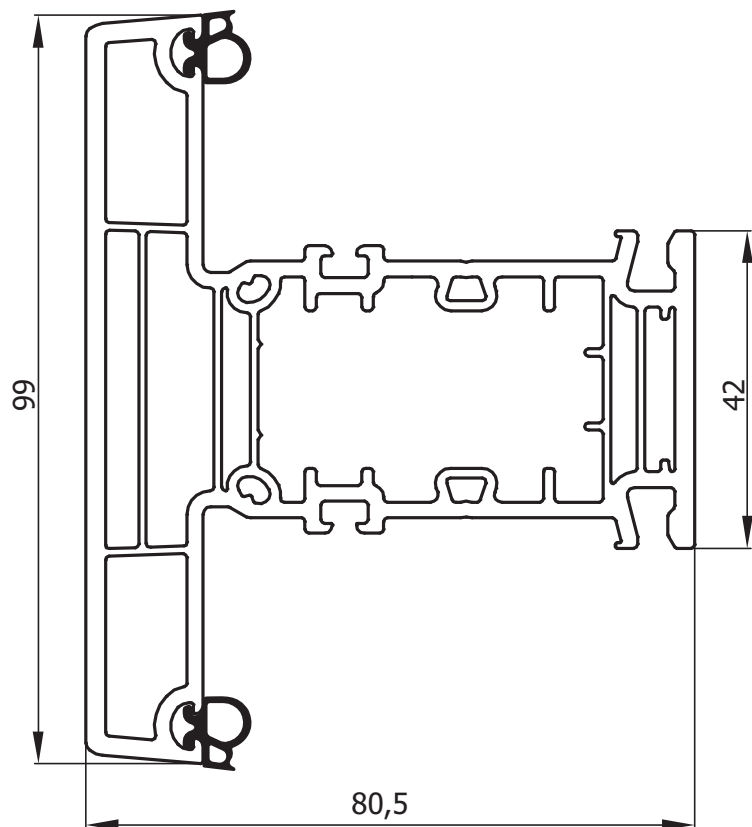

□	Lx	Ly
90-104-10	3,74	1,17
90-124-10	4,73	1,45
90-134-10	6,36	1,88

## Thermicco

### nr: 9132

Słupek ruchomy

Movable mullion

Beweglicher Pfosten

Импост подвижный

Pohyblivý stípič

Ştulp

Stulp

nr: 9132-0-1



nr: 9132-0-2

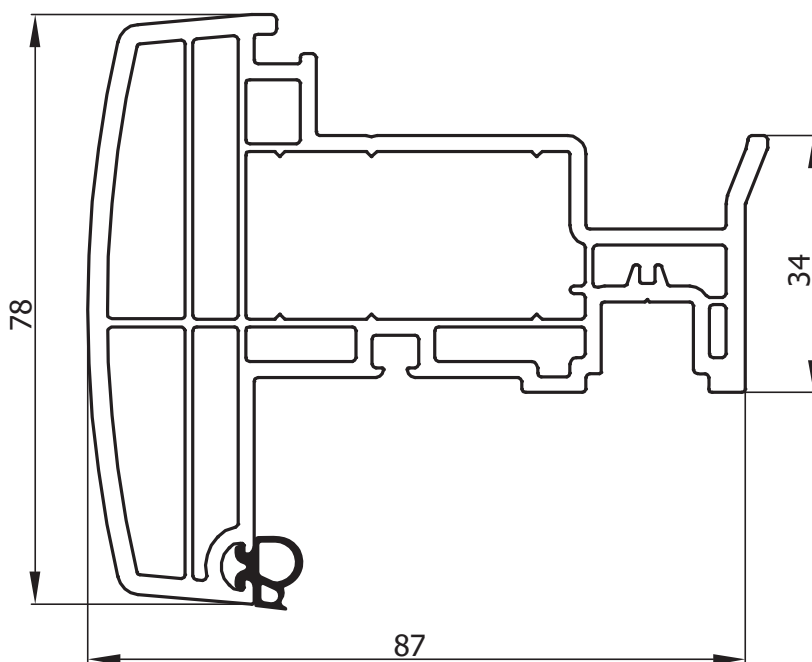

	Lx	Ly
90-104-10	3,74	1,17
90-124-10	4,73	1,45
90-134-10	6,36	1,88

## Thermicco

### nr: 9140

Listwa przyszybowa  
Glass bead  
Glasleiste  
Штапик стеклопакета  
с черным уплотнителем  
Zasklievacia lišta  
Şipcă la geam  
Üvegező léç

nr 9140-0-1



nr 9140-0-2

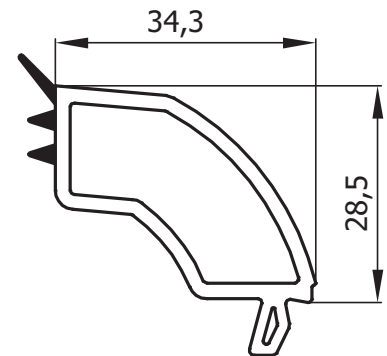

### nr: 9142

Listwa przyszybowa  
Glass bead  
Glasleiste  
Штапик стеклопакета  
Zasklievacia lišta  
Şipcă la geam  
Üvegező léç

nr 9142-0-1



nr 9142-0-2

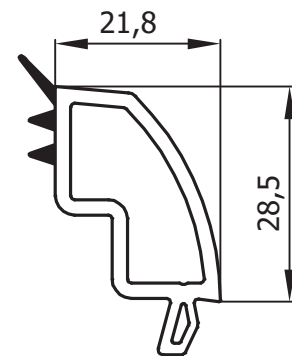

### nr: 9143

Listwa przyszybowa  
Glass bead  
Glasleiste  
Штапик стеклопакета  
Zasklievacia lišta  
Şipcă la geam  
Üvegező léç

nr 9143-0-1



nr 9143-0-2

